

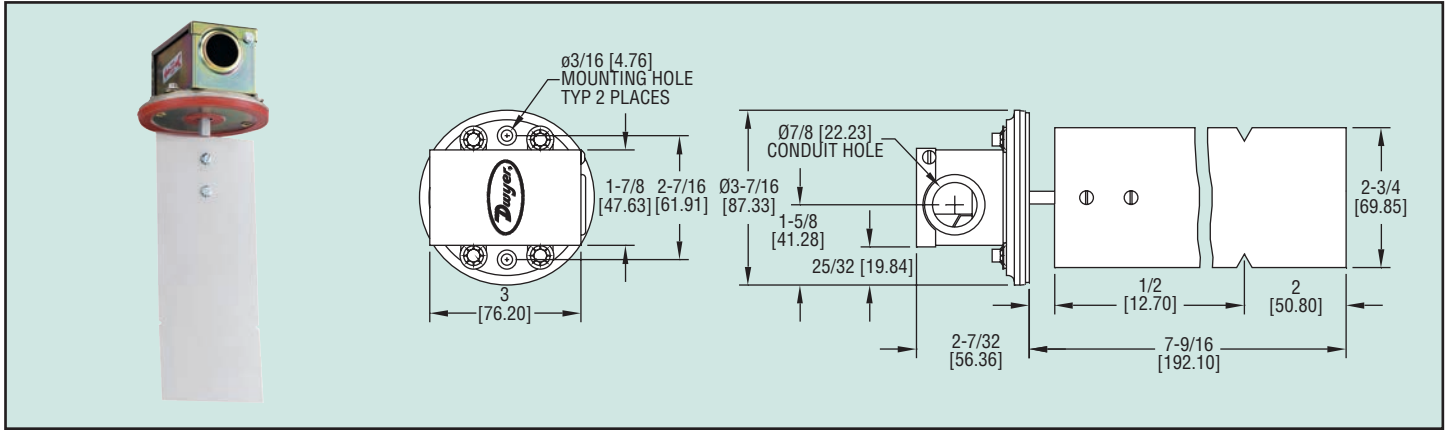

Model  
530

# Air Flow Switch

Adjustable from 400-1600 FPM, Stainless Steel Vane



The Model 530 air flow switch provides excellent sensitivity and reliability at a very reasonable price. Quality features include a rugged die cast body, stainless steel vane and SPDT snap switch. Unit is field adjustable from 400-1600 FPM. Mounting is fast and simple, with only two screws needed. Vane fits 6 in. or larger ducts.

## Model 530, Air Flow Switch

Range 400-1600 FPM mounted on top of horizontal duct.

**CAUTION:** For use only with air or non-combustible non-corrosive gases. Unit is not sealed against dust.

## SPECIFICATIONS

**Service:** Air and non-combustible gas flow.

**Wetted Materials:** Contact factory.

**Vane:** Stainless steel.

**Temperature Limit:** 180°F (82°C).

**Switch Type:** SPDT.

**Electrical Rating:** 125 VAC - 9.8 amp full load 58.8 amp locked rotor; 250 VAC - 4.9 amp full load 29.4 amp locked rotor; Pilot rating: 470 VA at 125, 250 VAC;

Resistive: 15 amp at 125, 250, or 480 VAC.

**Electrical Connections:** Screw type terminal.

**Conduit Connection:** 7/8" conduit hole.

**Mounting Orientation:** Horizontal duct flow.

**Set Point Adjustment:** Screw type.

**Weight:** 1 lb 1 oz (481.94 g)

**Agency Approvals:** CE, CSA, UL.